

Quick Installation Guide

IGPS-1042GPA

Industrial Unmanaged Gigabit PoE Switch

Introduction





IGPS-1042GPA is an unmanaged Ethernet Switch with 4x10/100/1000Base-T(X) P.S.E ports with 2x100/1000Base-X SFP ports and extended operating temperature range from -40°C to 75°C for the harsh environments. IGPS-1042GPA supports power over Ethernet, a system to transmit electrical power, along with data, to remote devices over standard twisted-pair cable in an Ethernet network. P.S.E is a device (switch or hub for instance) that will provide power in a PoE setup. Therefore, the switch is one of the most reliable choices for PoE Ethernet application.

Features

- > Support 4 ports 10/100/1000Base-T(X) P.S.E ports.
- > Support IEEE 802.3at compliant PoE and total power budget is 120Watts with maximum 30Watts per port.
- > Support auto-negotiation and auto-MDI/MDI-X
- > Support store and forward transmission
- > Support flow control
- > Support Jumbo frame up to 10K Bytes
- > Provide Relay output for power failed warning system
- > Rigid IP-30 housing design
- > DIN-Rail and wall mounting enabled

Package Contents

The device is shipped with the following items. If any of these items is missing or damaged, please contact your customer service representative for assistance.



Contents	Pictures	Number
IGPS-1042GPA		X 1
DIN-rail Kit		X 1
Wall-mount Kit		X 2
QIG		X 1
6-pin terminal block		X 1

Preparation

Before you begin installing the switch, make sure you have all of the package contents available and a PC with Microsoft Internet Explorer 6.0 or later, for using web-based system management tools.

Safety & Warnings

-  **Elevated Operating Ambient:** If installed in a closed or multi-unit rack assembly, the operating ambient temperature of the rack environment may be greater than room ambient. Therefore, consideration should be given to installing the equipment in an environment compatible with the maximum ambient temperature (T_{ma}) specified by the manufacturer.

-  **Reduced Air Flow:** Installation of the equipment in a rack should be such that the amount of air flow required for safe operation of the equipment is not compromised.
-  **Mechanical Loading:** Mounting of the equipment in the rack should be such that a hazardous condition is not achieved due to uneven mechanical loading.
-  **Circuit Overloading:** Consideration should be given to the connection of the equipment to the supply circuit and the effect that overloading of the circuits might have on overcurrent protection and supply wiring. Appropriate consideration of equipment nameplate ratings should be used when addressing this concern.

Dimension Unit =mm (Tolerance ±0.5mm)

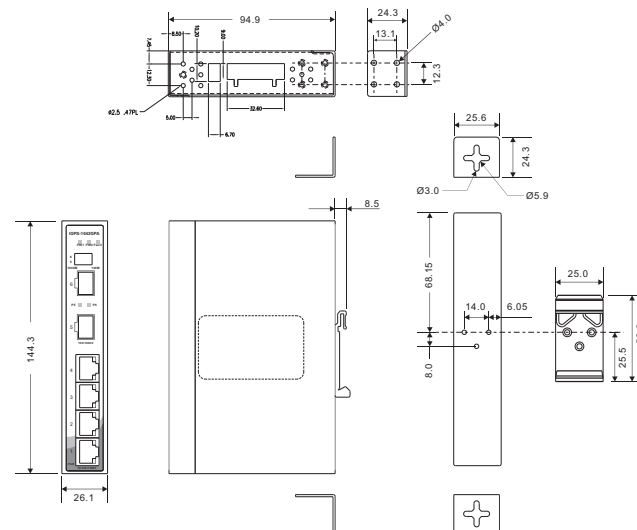

Panel Layouts

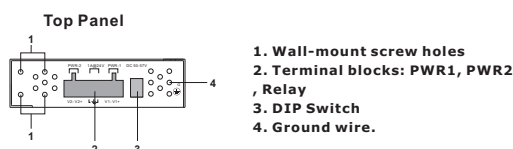
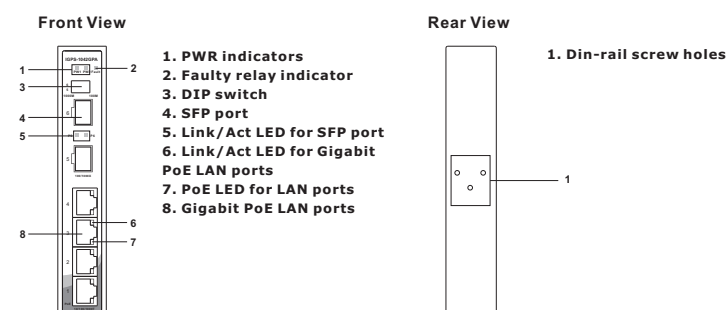

Installation

DIN-rail Installation

- Step 1:** Slant the switch and screw the Din-rail kit onto the back of the switch, right in the middle of the back panel.
- Step 2:** Slide the switch onto a DIN-rail from the Din-rail kit and make sure the switch clicks into the rail firmly.

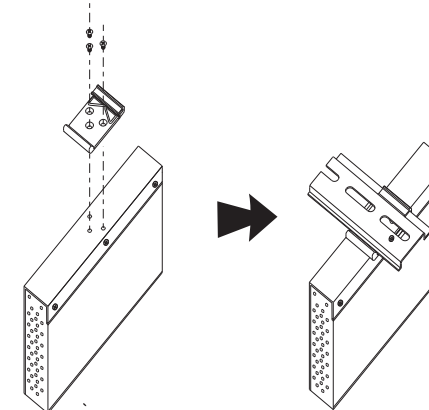

Wall-mounting

- Step 1:** Screw the wall-mount kit onto the rear panel of the switch. A total of six screws are required, as shown below.
- Step 2:** Use the switch, with wall mount plates attached, as a guide to mark the correct locations of the four screws.
- Step 3:** Insert a screw head through the large parts of the keyhole-shaped apertures, and then slide the switch downwards. Tighten the screws for added stability.

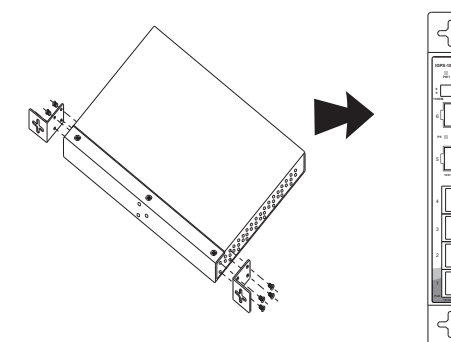

Network Connection

The switch provides standard Ethernet ports. According to the link type, the switch uses CAT 3,4,5e UTP cables to connect to any other network devices (PCs, servers, switches, routers, or hubs). Please refer to the following table for cable specifications.

Cable Types and Specifications:

Cable	Type	Max. Length	Connector
10BASE-T	Cat. 3, 4, 5 100-ohm	UTP 100 m (328 ft)	RJ-45
100BASE-TX	Cat. 5 100-ohm UTP	UTP 100 m (328 ft)	RJ-45
1000BASE-T	Cat. 5 / Cat. 5e 100-ohm UTP	UTP 100 m (328 ft)	RJ-45

For pin assignments for different types of cables, please refer to the following tables.

10/100Base-T(X) P.S.E. RJ-45 port		1000Base-T P.S.E. RJ-45 port	
Pin No.	Description	Pin No.	Description
#1	TD+ with PoE Power Input +	#1	Bl_DA+ with PoE Power Input +
#2	TD- with PoE Power Input +	#2	Bl_DA- with PoE Power Input +
#3	RD+ with PoE Power Input -	#3	Bl_DB+ with PoE Power Input -
#4	N.C.	#4	Bl_DC+
#5	N.C.	#5	Bl_DC-
#6	RD- with PoE Power Input -	#6	Bl_DB- with PoE Power Input -
#7	N.C.	#7	Bl_DD+
#8	N.C.	#8	Bl_DD-

Note: "+" and "-" signs represent the polarity of the wires that make up each wire pair.

DIP Switch Setting (Power Side)

DIP-1	DIP-2	Description
OFF	OFF	Power failure relay alarm disabled
ON	OFF	PWR-1 failure, relay alarm enabled
OFF	ON	PWR-2 failure, relay alarm enabled
ON	ON	PWR-1 or PWR-2 failure, relay alarm enabled

DIP Switch Setting (SFP Speed Selection)

DIP-1	DIP-2	Description
port 6	port 5	
OFF		100Mbps
ON		100Mbps

Wiring

Power inputs

The switch supports dual redundant power supplies, Power Supply 1 (PWR1) and Power Supply 2 (PWR2). The connections for PWR1, PWR2 and the RELAY are located on the terminal block.

STEP 1: Insert the negative/positive wires into the V-/V+ terminals, respectively.

STEP 2: To keep the DC wires from pulling loose, use a small flat-blade screwdriver to tighten the wire-clamp screws on the front of the terminal block connector.

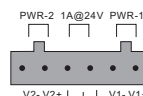

Relay contact

The two sets of relay contacts of the 6-pin terminal block connector are used to detect user-configured events. The two wires attached to the fault contacts form an close circuit when a user-configured event is triggered. If a user-configured event does not occur, the fault circuit remains opened.

Grounding

Grounding and wire routing help limit the effects of noise due to electromagnetic interference (EMI). Run the ground connection from the ground screws to the grounding surface prior to connecting devices.

Configurations

After installing the switch, the green power LED should turn on. Please refer to the following tablet for LED indication.

LED	Color	Status	Description
PW1	Green	On	DC power 1 activated
PW2	Green	On	DC power 2 activated
Fault	Amber	On	Faulty relay (power failure or port disconnected)
10/100/1000Base-T(X) Gigabit PoE Ethernet ports			
LNK/ACT	Green	On	Port link at 1000Mbps
	Amber	On	Port link at 10/100Mbps
PoE	Green	On	Power supplied over Ethernet
SFP Port			
LNK/ACT	Green	On	Port is linked

Specifications

ORing Switch Model	IGPS-1042GPA
Physical Ports	
10/100/1000Base-T(X) P.S.E. Port in RJ45 Auto MDI/MDIX	4
100/1000Base-X SFP port	2
Technology	
Ethernet Standards	IEEE 802.3 for 10Base-T IEEE 802.3u for 100Base-TX IEEE 802.3ab for 1000Base-T IEEE 802.3z for 1000Base-X IEEE 802.3x for Flow control IEEE 802.3at PoE specification
MAC Table	1024
Packet buffer	1M bits
Processing	Store-and-Forward
Jumbo Frame	Up to 10KBytes
Switch Properties	Switching latency: 7 us Switching bandwidth: 12Gbps Throughput (packet per second) : 8.688Mpps@64Bytes packet
LED Indicators	
Power indicator	Green: Power LED x2
Fault indicator	Amber: Indicate PWR1 or PWR2 failure
10/100/1000Base-T(X) RJ45 port indicator and PoE indicator	Upper LED for Link/Act indicator: Green for port Link/Act Lower LED for PoE indicator, Green for PoE power enable
100/1000Base-X SFP port indicator	Green for port Link/Act.
DIP Switch for SFP port speed	
DIP switch 1 (SFP Port 6)	ON: 100Mbps, OFF: 1000Mbps(default)
DIP switch 2 (SFP port 5)	ON: 100Mbps, OFF: 1000Mbps(default)
DIP Switch for power fail alarm	
DIP-Switch 1	Power 1 fail warning: ON for Enable, OFF for disable
DIP-Switch 2	Power 2 fail warning: ON for Enable, OFF for disable
Fault Contact	
Relay	Relay output to carry capacity of 1A at 24 VDC
Power	
Redundant Input power	Dual 50~57VDC on 6-pin terminal block
Power consumption(Typ.)	<6.5Watts, 0.13-0.11A
PoE Power Budget	120W max, 30W per port
Overload current protection	Present
Reverse polarity protection	Present
Physical Characteristic	
Enclosure	IP-30 Metal
Dimension (W x D x H)	26.1 (W) x 94.9 (D) x 144.3 (H) mm (1.03 x 3.74 x 5.68 inches)
Weight (g)	458g
Hardware Version	V5.0

Environmental	
Storage Temperature	-40 to 85°C (-40 to 185°F)
Operating Temperature	-40 to 75°C (-40 to 167°F)
Operating Humidity	5% to 95% Non-condensing
Regulatory Approvals	
EMC	CE EMC (EN 55024, EN 55032), FCC Part 15 B
EMI	EN 55032, CISPR32, EN 61000-3-2, EN 61000-3-3, FCC Part 15 B class A
EMS	EN 55024 (IEC/EN 61000-4-2 (ESD: Contact 4kV, Air 8kV), IEC/EN 61000-4-3 (RS: 3V), IEC/EN 61000-4-4 (EFT Power 0.5kV, Signal 1kV), IEC/EN 61000-4-5 (Surge: Power 0.5kV, Signal 1kV), IEC/EN 61000-4-6 (CS: 3V), IEC/EN 61000-4-8(PFMF), IEC/EN 61000-4-11 (DIP))
Shock	IEC60068-2-27
Free Fall	IEC60068-2-31
Vibration	IEC60068-2-6
Safety	EN 60950-1 (LVD)
MTBF	910925 hours
Warranty	5 years

ORing

Copyright© 2013 ORing
All rights reserved.

ORing Industrial Networking Corp.
TEL: +886-2-2218-1066 Website: www.oringnet.com
FAX: +886-2-2218-1014 E-mail: support@oringnet.com